

## FEEDALL Model 4800-HD Elevating Hopper Feeder w/1650-80RC-96 Cross-Feed Conveyor & SD-60-70-7,000# Hydraulic Tub Dumper

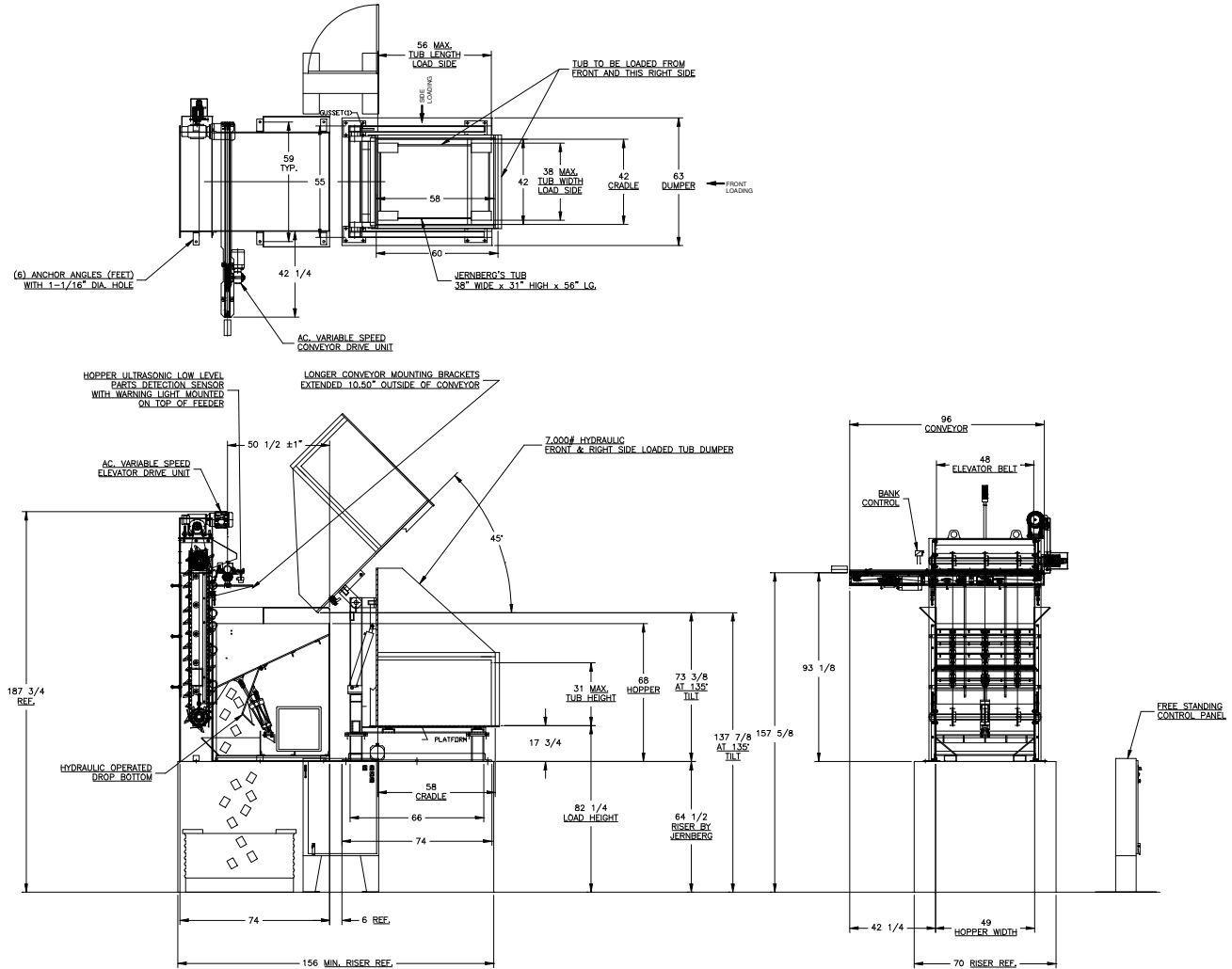

- APPLICATION:** Feed from a random loaded floor mounted hopper. The billets will be elevated from the hopper via cleated belt and deposited onto a cross-feed conveyor. The conveyor will translate the parts in a continuous stream onto a model 1650 conveyor.
- BELT WIDTH:** 48" Wide Elevating Belt
- DRIVE:** 3 HP/AC Motor
- PARTS FED (SIZE):** Steel Billets (Part Matrix)
- FEED RATE:** 16 Parts/Minute
- MACHINE FED:** Induction Heater