

FEEDALL Model 2400-D Elevating Hopper Feeder

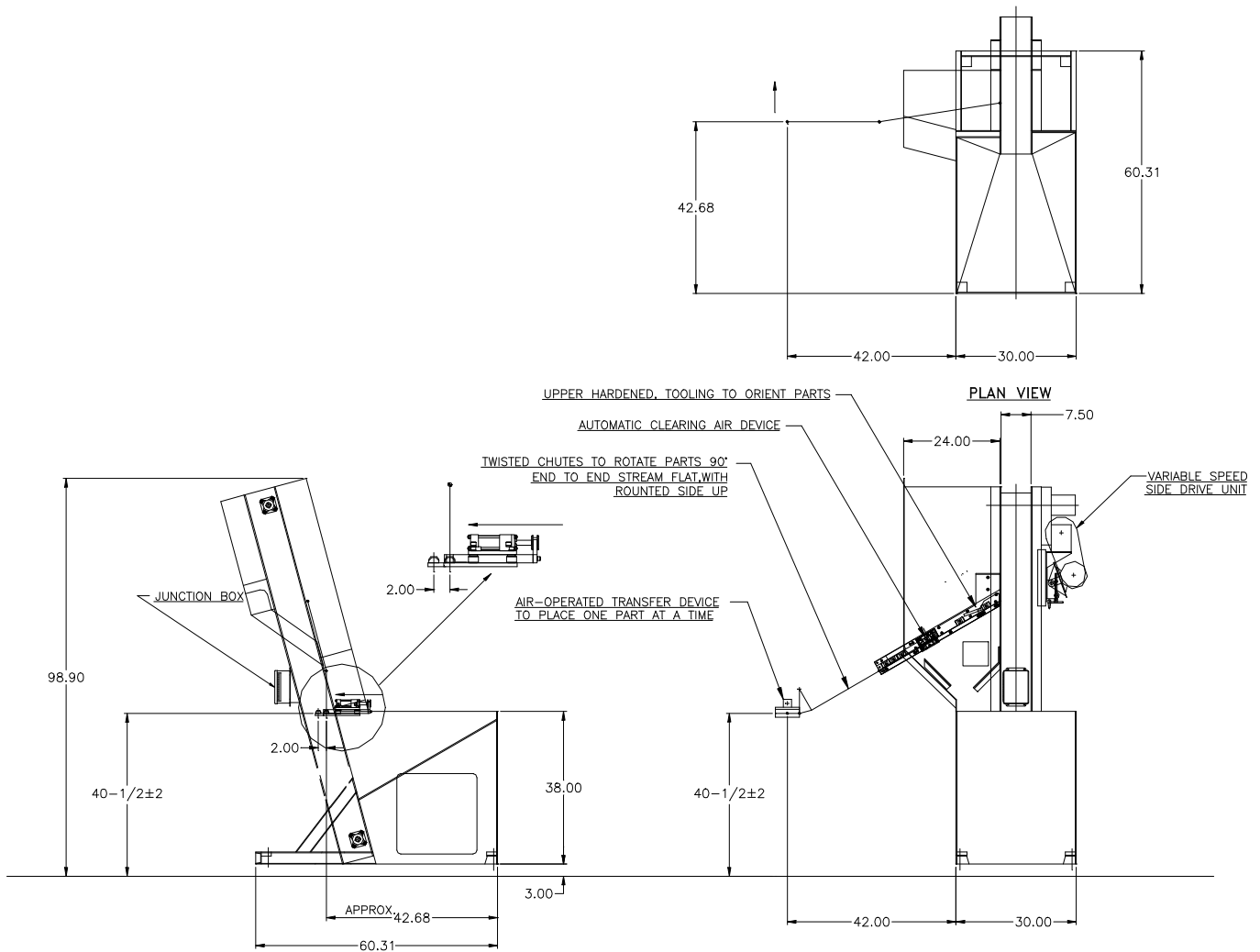

- APPLICATION:** Feed from a random loaded, floor mounted hopper. The Anchor Nuts will be elevated out of the hopper and discharged in a continuous end-to-end stream flat, with rounded side up. The parts will then be transferred one at a time for customer pick up.
- BELT WIDTH:** 7-1/2" Wide Table-Top Chain
- DRIVE:** 1/2 HP/AC Motor
- PARTS FED (SIZE):** Anchor Nuts (.764" thick by 1.306" wide by 2.300" long)
- FEED RATE:** 30 Parts/Minute
- MACHINE FED:** Tapping Machine