

FEEDALL Model 1700-B Magazine Bar Feeder

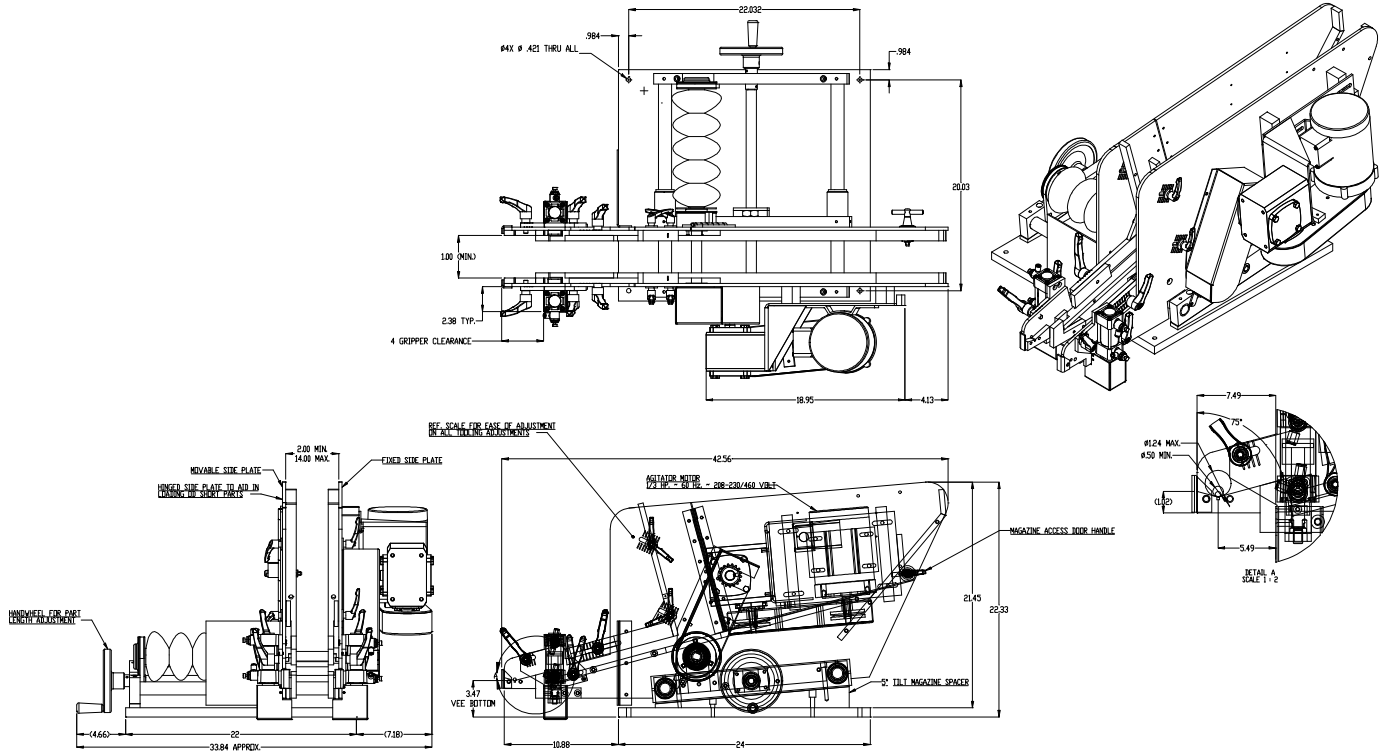

- APPLICATION:** Feed Steel Bars from a manually loaded, floor mounted magazine. Bars will be fed in a continuous stream and escaped one at a time rolling onto a hardened steel v-nest.
- WIDTH:** Adjustable
- DRIVE:** 1/4 HP/AC Motor
- PARTS FED (SIZE):** Steel Bars (0.50"-1.24"Ø x 3.00"-14.00" Lg.)
- FEED RATE:** 4 parts/minute
- MACHINE FED:** Robot Loaded Induction Heater