

FEEDALL Model 1700-B Magazine Bar Feeder

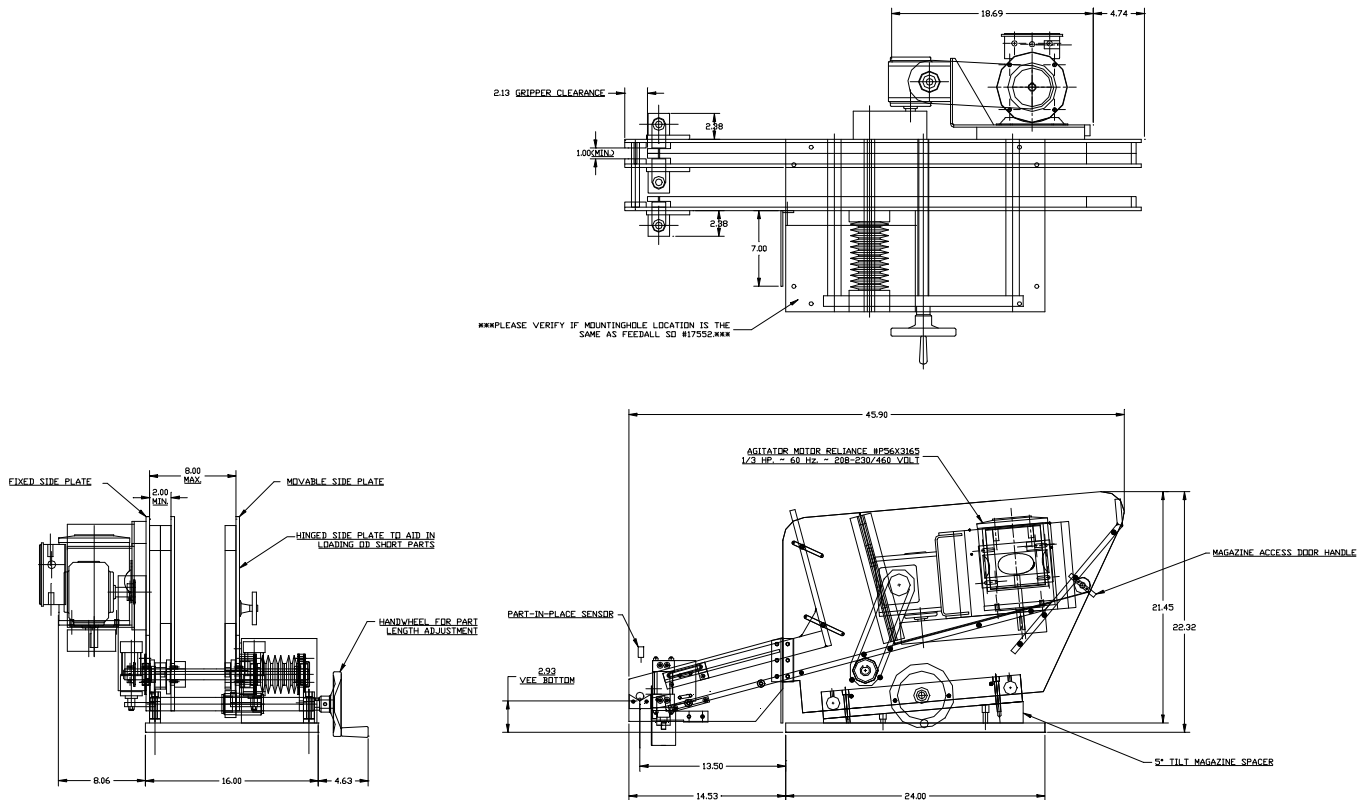

- APPLICATION:** Feed bars from a manually loaded, floor mounted magazine. Then will be fed in a continuous stream and escaped one at a time rolling onto a hardened steel v-nest.
- WIDTH:** 2"-6" (Adjustable)
- DRIVE:** 1/4 HP/AC Motor
- PARTS FED (SIZE):** Steel Bars (0.25"-0.75"Ø x 2.00"-6.00" Lg.)
- FEED RATE:** 4 Parts/Minute
- MACHINE FED:** Robot Loaded Induction Heater