

FEEDALL Model 1700 Magazine Bar Feeder

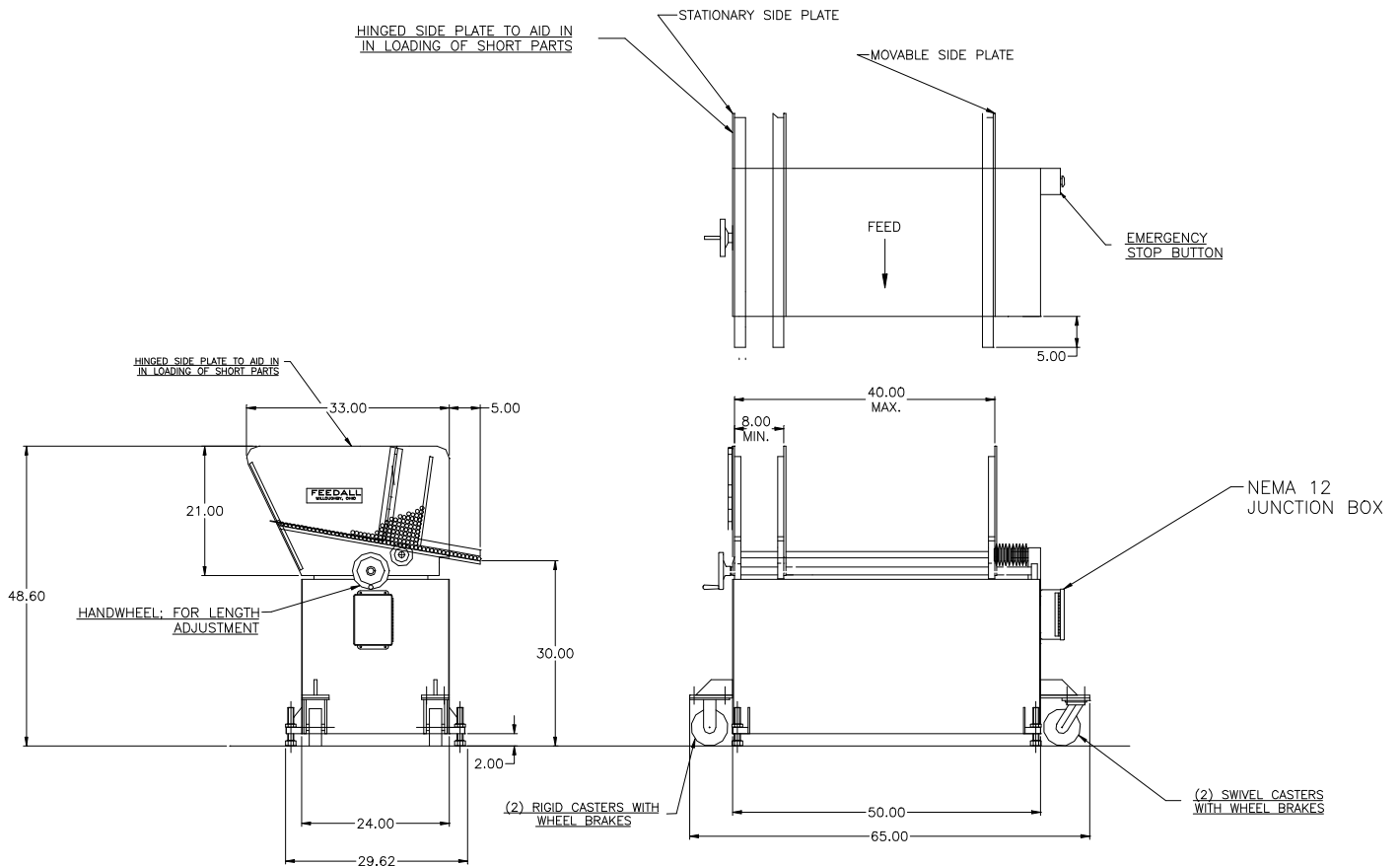

- APPLICATION:** Feed from a manually loaded, floor mounted magazine. The Steel Tubes will be fed in a continuous stream and escaped one at a time into the load magazine of customers end finishing machine.
- WIDTH:** 8"-40" (Adjustable)
- DRIVE:** 1/4 HP/AC Motor
- PARTS FED (SIZE):** Steel Tubes (0.50"Ø x 8.00"-40.00" Lg.)
- FEED RATE:** 2,000 Parts/Hour
- MACHINE FED:** HAVEN End Finisher