

FEEDALL Model 1700 Magazine Bar Feeder

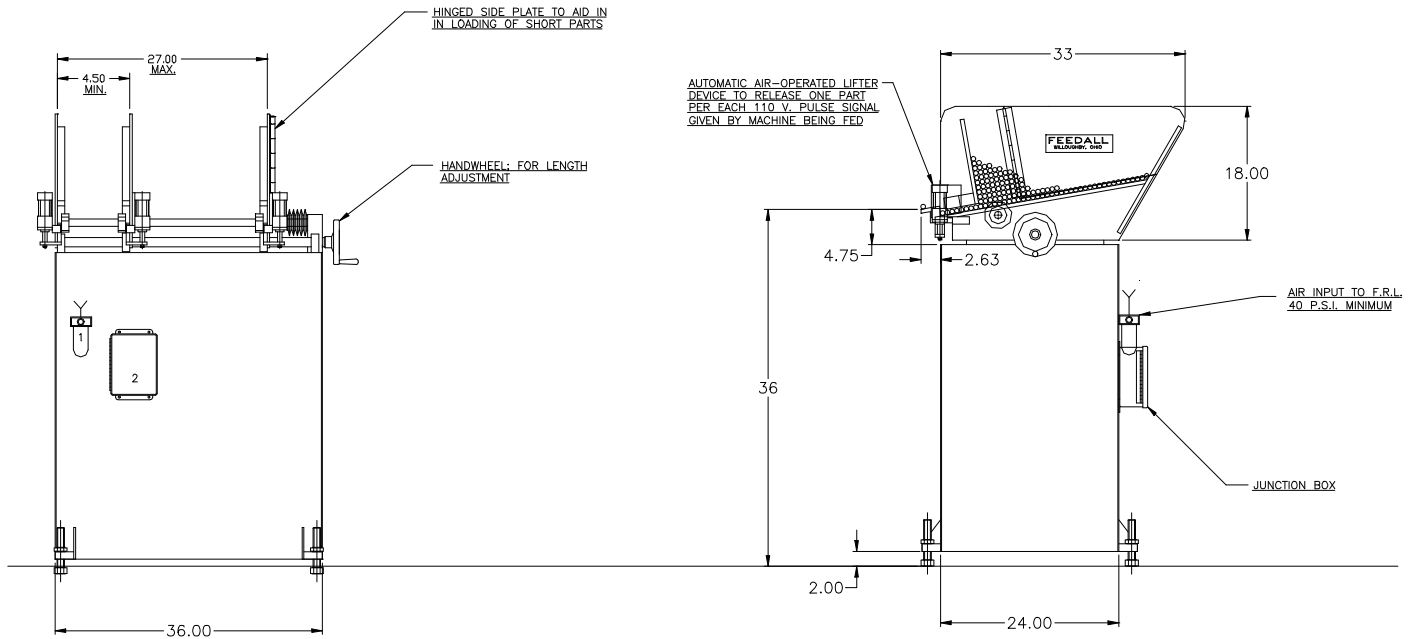

- APPLICATION:** Feed from a manually loaded floor mounted magazine. The Steel Shafts will be discharged one at a time rolling diameter to diameter per each signal given by the Broach Machine.
- WIDTH:** 4-1/2"-27" (Adjustable)
- DRIVE:** 1/4 HP/AC Motor
- PARTS FED (SIZE):** Motor Shafts (0.50"Ø x 4.50"-27.00" Lg.)
- FEED RATE:** 12 Parts/Minute
- MACHINE FED:** Broach