

## FEEDALL Model 1650-HD Entrance Conveyor

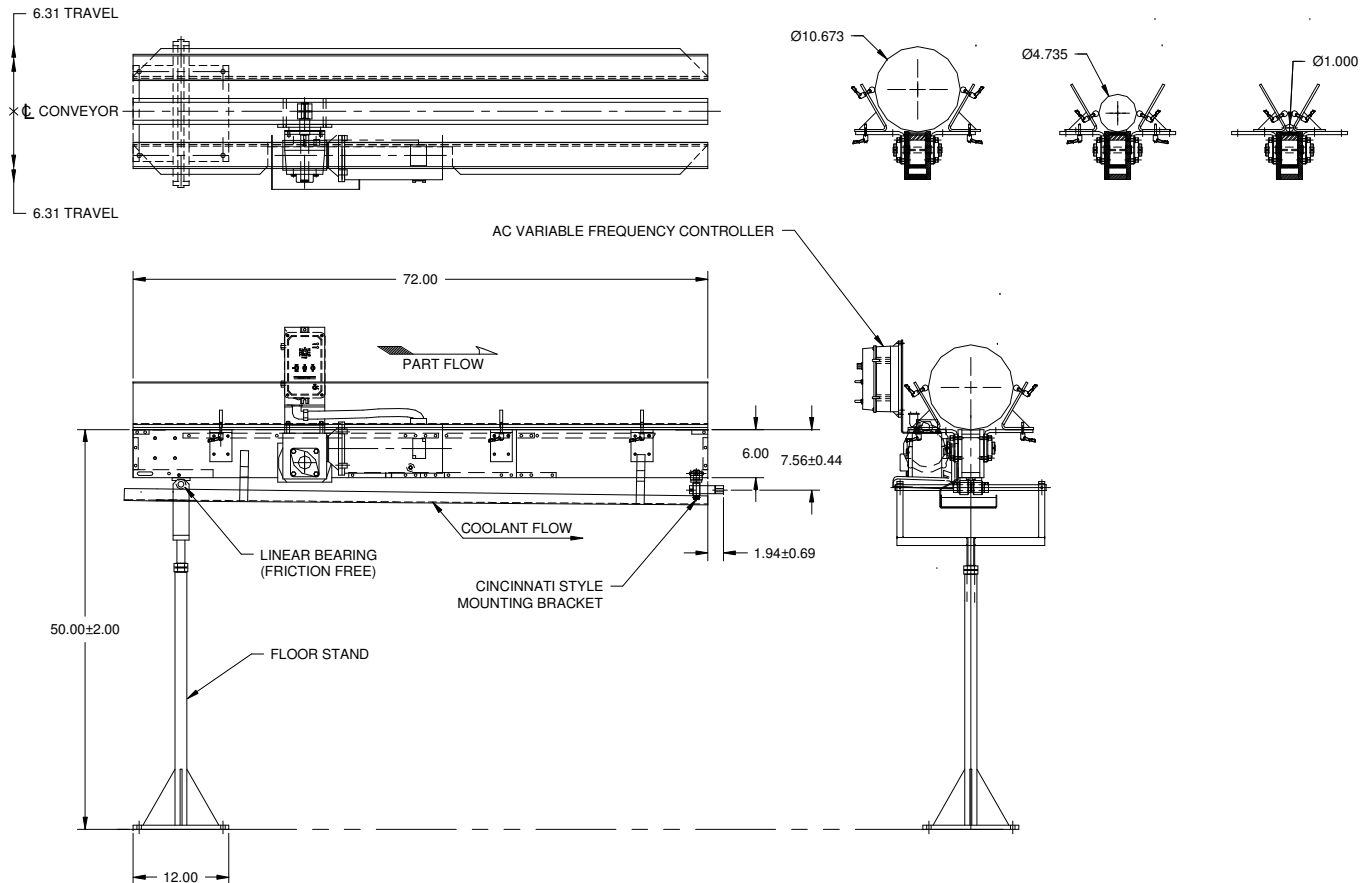

- APPLICATION:** Convey Bearing Races to the workrest of a Centerless Grinder.
- BELT WIDTH:** 2" Wide Silent Chain
- DRIVE:** 1/2 HP/AC Motor w/Variable Frequency Controller
- PARTS FED (SIZE):** Bearing Races (1.000"-10.673"Ø x 1.225"-3.161" Lg.)
- FEED RATE:** 1-50 Feet/Minute
- MACHINE FED:** CINCINNATI #4 Centerless Grinder