

FEEDALL Model 1650-2SC-72 Entrance Conveyor

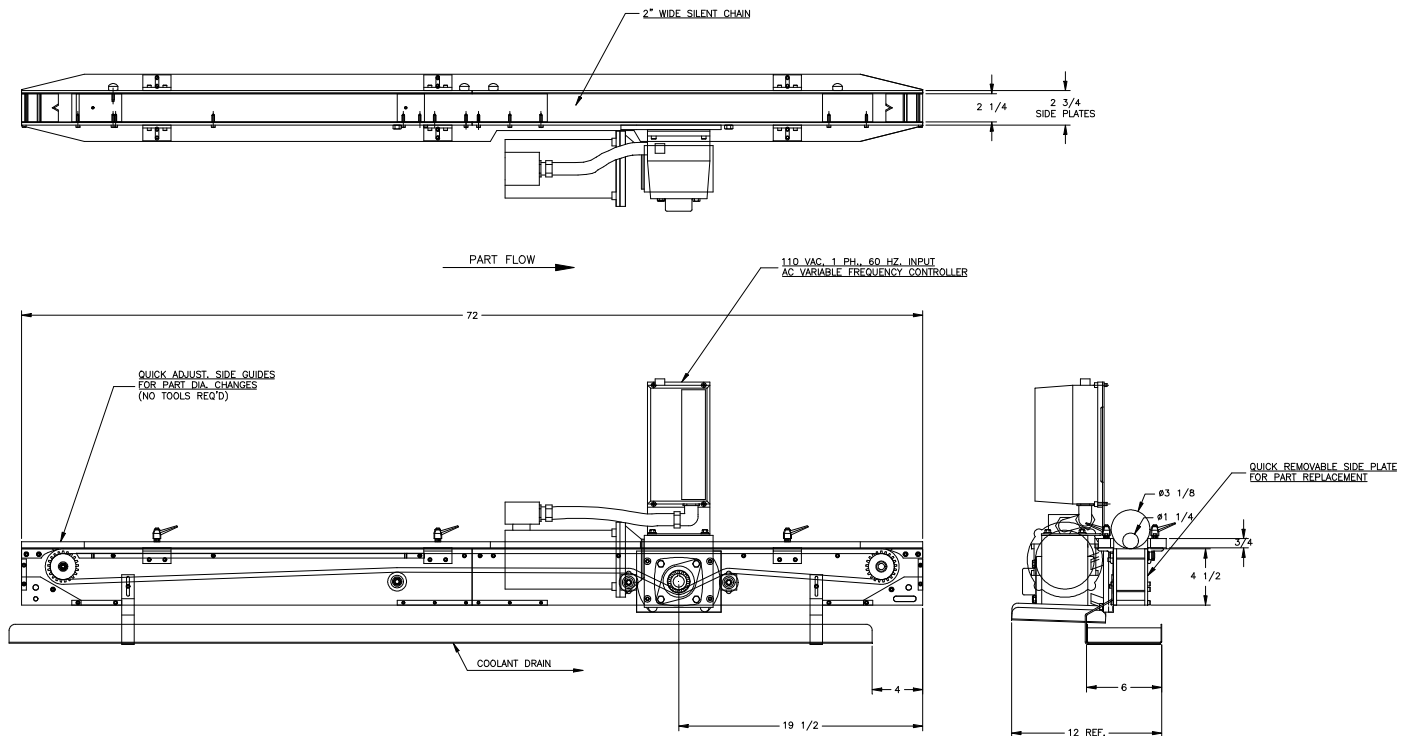

APPLICATION:	Convey Pinion Shafts to the workrest of a CINCINNATI Model 325 Centerless Grinder.
BELT WIDTH:	2" Wide Silent Chain
DRIVE:	1/4 HP/AC Motor w/Variable Frequency Controller
PARTS FED (SIZE):	Pinion Shafts (1.23"-3.09"Ø x 3.44"-9.51" Lg.)
FEED RATE:	1-50 Feet/Minute
MACHINE FED:	CINCINNATI Model 325 Centerless Grinder