

## FEEDALL Model 1650-2SC-62-1/2 Entrance Conveyor

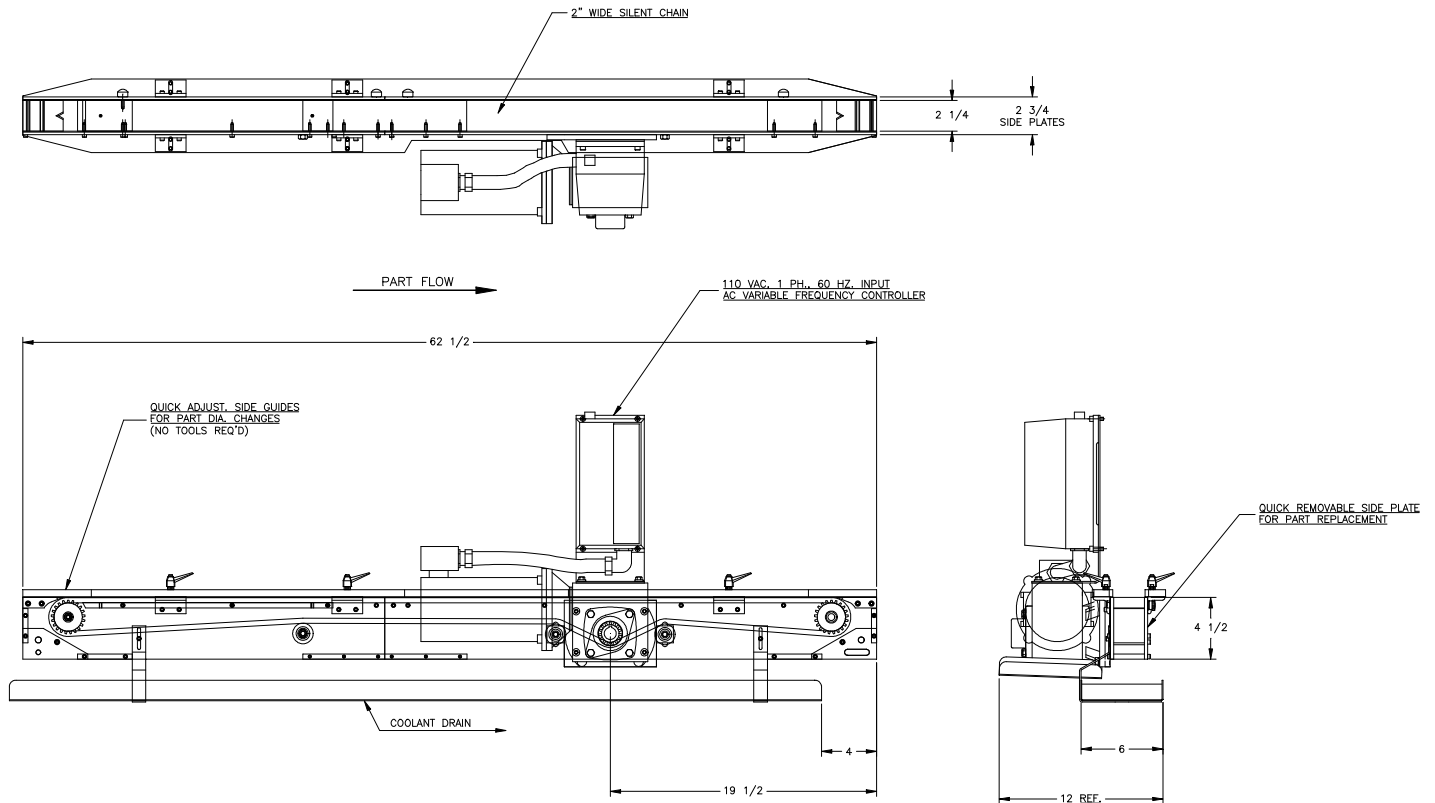

- APPLICATION:** Convey Motor Rotors to the workrest of a Centerless Grinder.
- BELT WIDTH:** 2" Wide Silent Chain
- DRIVE:** 1/3 HP/AC Motor w/Variable Frequency Controller
- PARTS FED (SIZE):** Motor Rotors (2.50"-3.38"Ø x 2.63"-7.25" Lg.)
- FEED RATE:** 1-50 Feet/Minute
- MACHINE FED:** Centerless Grinder