

FEEDALL Model 1650-1PB-72 Entrance Conveyor

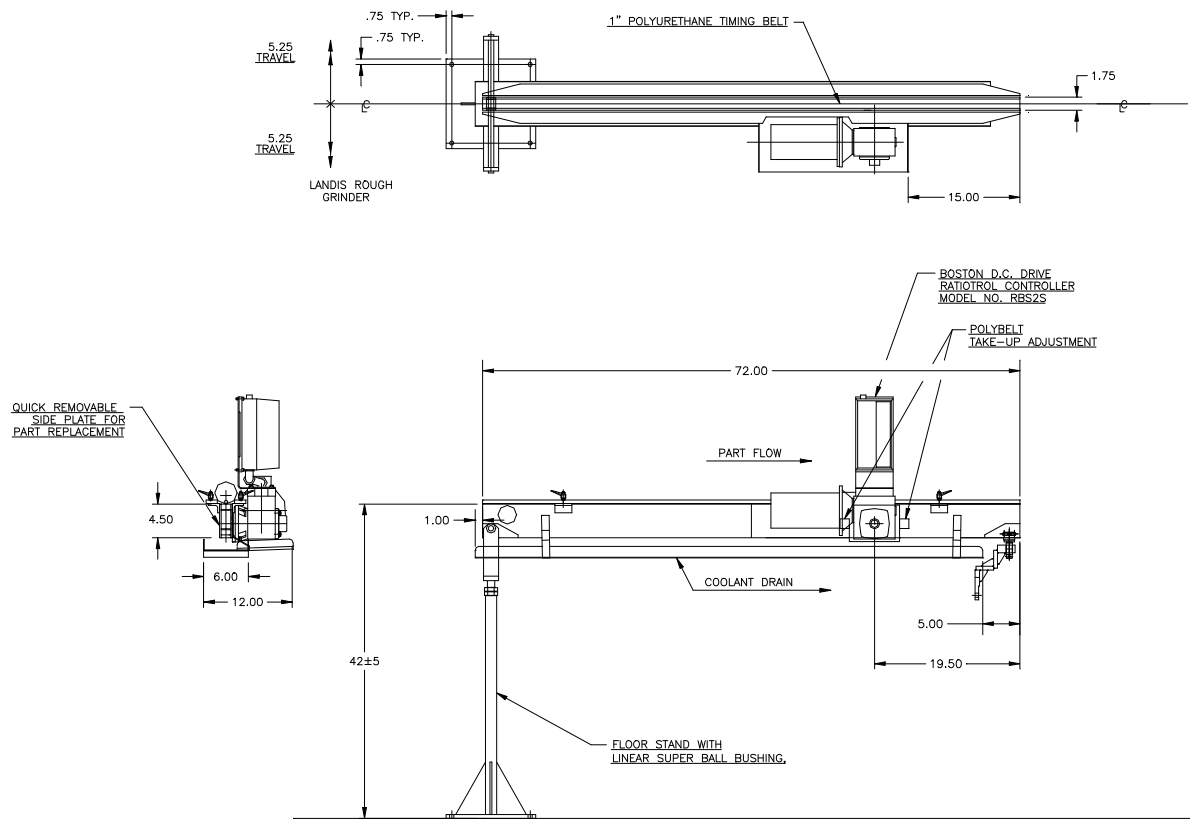

- APPLICATION:** Convey Shafts to the workrest of a LANDIS Centerless Grinder.
- BELT WIDTH:** 1" Polyurethane Timing Belt
- DRIVE:** 1/4 HP/AC Motor w/Variable Frequency Controller
- PARTS FED (SIZE):** Steel Shafts (0.75"-1.00"Ø x 18.00"-35.00" Lg.)
- FEED RATE:** 1-50 Feet/Minute
- MACHINE FED:** LANDIS Centerless Grinder