

FEEDALL Model 0600 Elevating Bulk Hopper Feeder

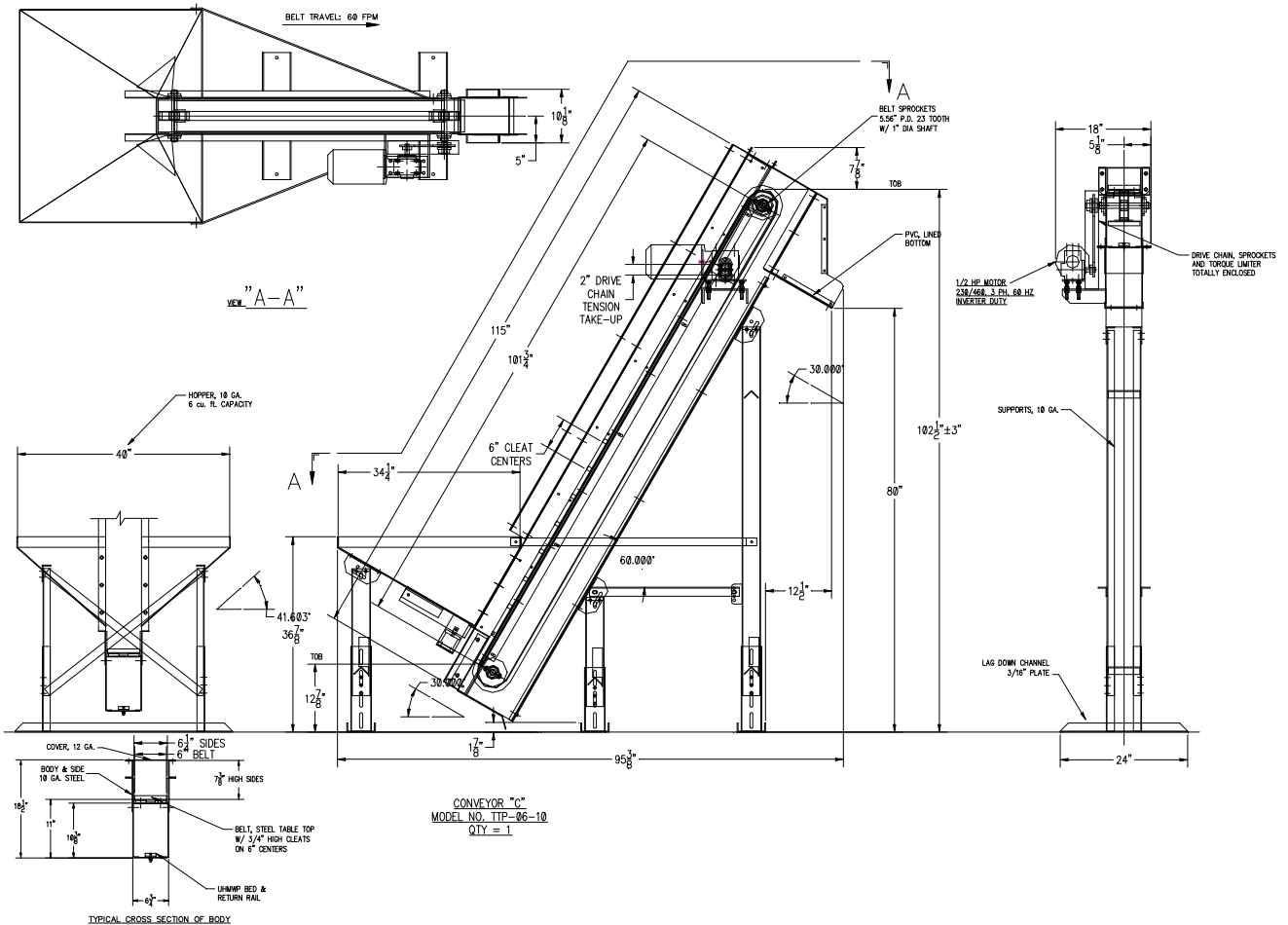

- APPLICATION:** Feed from a random loaded floor mounted hopper. Parts will be elevated from hopper via a clefted belt and discharged randomly into a customer supplied vibratory bowl.
- BELT WIDTH:** 6" Wide Table-Top Chain Elevating Belt
- DRIVE:** 1/2 HP/AC Motor
- PARTS FED (SIZE):** Forged Brass Pipe Fittings (Part Matrix)
- FEED RATE:** 15 Parts/Minute
- MACHINE FED:** Vibratory Bowl