

## FEEDALL Model 1500 Bi-Directional Orienting Conveyor w/GLH-3.5-4 Exit Conveyor

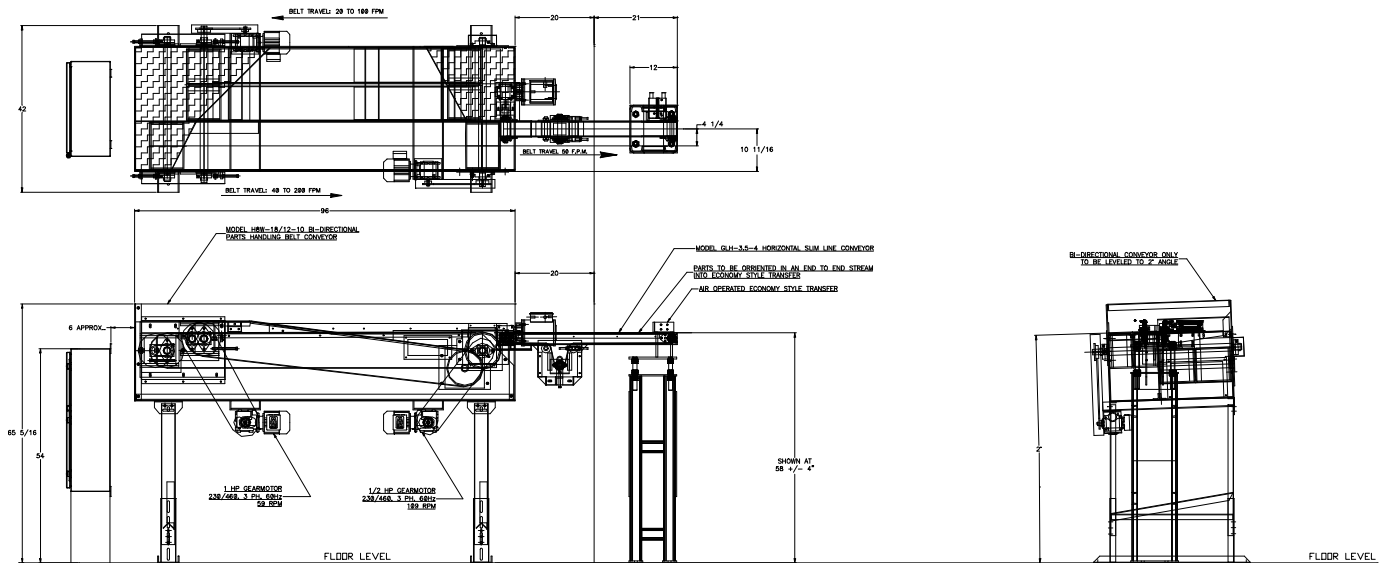

- APPLICATION:** Feed from a random loaded floor mounted hopper. The parts will metered from a customer supplied elevator on demand and spilled randomly onto a bi-directional feed conveyor. The parts will merge from the infeed conveyor portion onto the orienting conveyor lane and exit in a continuous stream to an automatic air operated ECONOMY STYLE TRANSFER DEVICE. Then the parts will be loaded in a diameter-to-diameter stream into an existing load chute.
- BELT WIDTH:** 18" Return Lane and a 12" Orienting Lane
- DRIVE:** 1-1/2 HP/AC Motor
- PARTS FED (SIZE):** Steel Tubes (0.500"-2.375"Ø x 2.000"-8.000" Lg.)
- FEED RATE:** 20 parts/minute
- MACHINE FED:** End Finisher